



BTA-HON03

BLUETOOTH INSTALL GUIDE FOR HONDA/ACURA WITH SAT RADIO TUNER, REMOTE CD CHANGER* AND/OR RSE

Created January 16, 2024

Revised January 28, 2025

PRODUCT SAFETY & DISCLAIMER

READ ALL INSTRUCTIONS CAREFULLY BEFORE INSTALLING, FAILURE TO DO SO MAY CAUSE PERSONAL INJURY OR DAMAGE TO PRODUCT AND/OR PROPERTY

- This installation guide is provided as a GENERAL installation guide, some vehicles vary and may require additional steps. We do not accept responsibility for third party labor charges or modifications. Exercise due-diligence when installing this product.
- We do not accept any responsibility for vehicle damage or personal injury resulting from the installation of this product.
- Careless installation and operation can result in equipment damage.

Requirements:

VEHICLES WITH REMOTE CD CHANGER* RSE AND/OR SATELLITE RADIO TUNER

Introduction:

Just because you drive an older car does not mean you settle for old technology. The BTA-HOND3 updates select 2003-12 Honda/Acura to support music a streaming connection from Smartphone, Tablet, Kindle and more.

The BTA-HOND3 module connects to the radio 14-pin socket and **requires and retains factory options** such as remote CD changer*, RSE(DVD) or Satellite radio tuner (With or without subscription)

Vehicle must have at least one factory option for the BTA-HOND3 to work, otherwise purchase our [A2D-HOND3](#).

After a short paring session, users are able to enjoy the best sound possible on the car speakers while also retain use of the remote CD changer, Satellite radio tuner broadcast (if subscribed) or RSE.

Regardless of subscription status, vehicle must have at least one factory option (Sat tuner or a remote CD changer or RSE) otherwise the BTA-HOND3 will not function. See **Frequently Asked question** at the end of this guide for more details.

*All CD changer references made herein are not to the CD changer built-into Honda/Acura AM/FM radio but optional 6-disc changer in remote area (glovebox, trunk, hatch etc.).

Installation:

1. Remove factory radio from dashboard to gain access to the connectors. (Vehicle specific radio removal instructions are not part of this guide, but may be available upon request)
2. Disconnect factory 14-pin plug (See **Fig. 1**) from radio 14-pin connector (See **Fig. 2**)

Alert: If the radio 14-pin connector is empty, (See **Fig. 2**) there is no need to proceed with the install because vehicle does not have a factory option required for the BTA-HOND3 to function.

3. Connect factory 14-pin plug (from step 2), to installation harness 14-pin connector. (See **Fig. 3**)



Fig. 1



Fig. 2



Fig. 3

4. Connect installation harness 14-pin plug (See Fig. 1) to the radio 14-pin connector vacated in step 2. (See Fig. 2)

AUX JACK INSTALLATION: (Expired Satellite radio subscription only) otherwise skip to step 8

5. The aux jack (See Fig. 4) is available only if Satellite radio (expired subscription) option was selected. Route jack to location on dash or nearby panel where it will be mounted (within 3 ft.) final location will vary based on vehicle and customer's preference.



AUX Input jack
Fig. 4

6. **Optional mounting:** Drill a 15/64 or 1/4" hole in dash or panel, push aux jack shaft through and secure with nut (See Fig. 5)



Fig. 5

Alert: Aux jack may be left freestanding, but if mounted; ensure panel is **less than 4mm thick** otherwise shaft may not protrude enough to engage with nut. If necessary, use dremel, sander etc. to thin panel or choose alternate mounting location.

8. Connect module installation harness 16-pin plug (See Fig. 6) to module 16-pin connector (See Fig. 7)

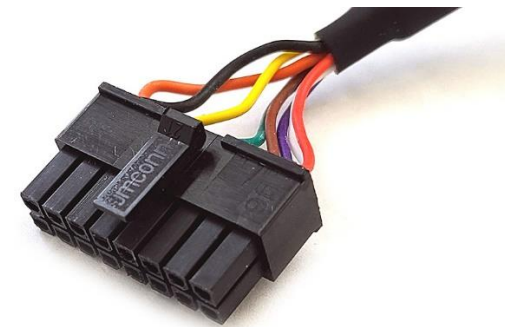

Fig. 6



Fig. 7

9. Connect/tap installation harness accessory wire (See Fig. 6) to pin 2 (yellow/red) accessory wire on radio main 20-pin plug (See Fig. 8) or locate alternate 12V switched supply.



Fig. 8

Honda 20-pin plug

Alert: Please ensure installation harness red wire is powered only when ignition is turned on, otherwise risk draining car battery.

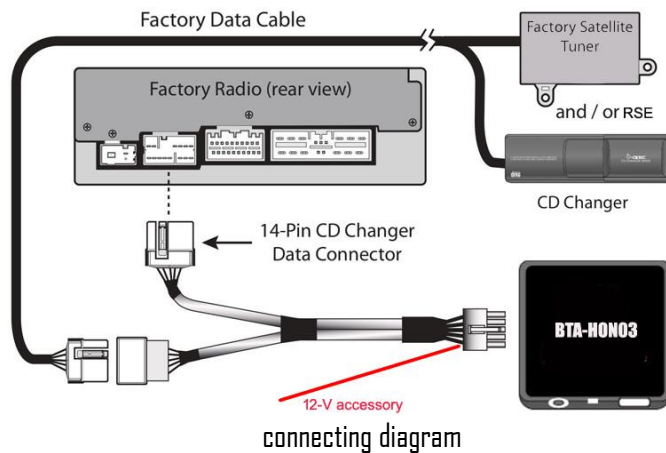

Optional USB extension cable installation

Please note: Optional USB dash mount extension cable is not required for operation; however, it extends the module USB port (See Fig. 11) to dashboard, glovebox etc. and **USB port supports software updated and charging only**

1. Drill a $\frac{3}{4}$ " hole to dash or panel using a step drill bit or equivalent (See Fig. 9) As an alternative; use the included bracket (See Fig. 14) to mount USB without drilling.



Fig. 9

2. Fish USB cable terminal (See Fig. 9) through hole created in step 1 and plug into USB port on module (See Fig. 10)



Fig. 10
USB cable



Fig. 11

3. Snap header (See Fig. 11) to surface until flush (See Fig.12)



Fig. 12



Fig. 13



Fig. 14

4. Secure module and proceed to pairing

Pairing

Pairing varies among devices but basic steps are the same. This process is done upon initial install and will not have to be repeated

1. Turn ignition and radio "ON"
2. From your Bluetooth enabled device, turn the Bluetooth ON and search for Bluetooth devices.
3. When a list of available Bluetooth devices appears on your Bluetooth device, select "DisCarSt" (See Fig. 15)
4. Confirmation "tone" is heard on car speakers.
5. The unit will automatically enter the BT Audio source and you can now start streaming audio from your Bluetooth enabled device.

Note: If the mobile phone doesn't support SSP (Simple Secure Pairing) Profile, please enter the pass code of "0000"

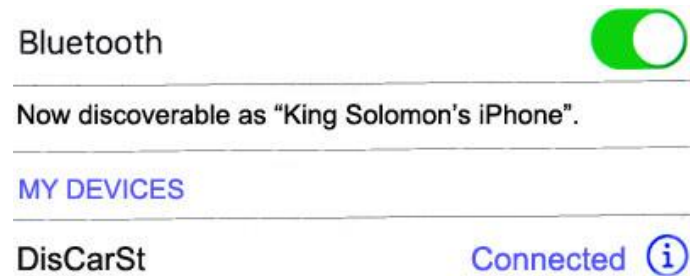

Fig. 15

Operation

1. Turn ignition and radio "ON"
2. Press "CD", "DISC" "AUX", "SAT" or "XM" button to enter Bluetooth mode (See Fig. 16)



Fig. 16

3. On smart device, Launch streaming application of choice
4. Use wireless remote buttons or device built-in controls to change tracks adjust device volume, pause etc. (See Fig. 17)
5. To listen to Satellite radio broadcast (if subscribed) or remote CD changer or RSE tap **Pause/Play** on remote control. (switching may take 3-4 seconds)
6. To switch back to streaming, tap **Pause/Play** button on remote control
7. To listen to "AUX" device (With Satellite radio tuner/not subscribed), tap **Pause/Play** button on remote control

Notes: 1. To adjust volume (+/-) use tapping action instead of tap and hold
2. If vehicle has only a remote CD changer, at least 1 disc must remain in changer magazine.



Fig. 17

8. If correct operation is confirmed go ahead and reinstall radio.

Frequent asked questions & troubleshooting:

1. **Will the BTA-HON03 work in vehicles with a 6-CD changer radio? (Changer built-into AM/FM radio)**
YES; but vehicle must also have a Satellite radio tuner or remote CD changer) or RSE. Satellite radio tuner subscription may be expired or active.
2. **Can I use the BTA-HON03 to make hands-free calls?**
NO; The BTA-HON03 support music streaming but **does not** support hands-free-calls. —See our [BT3-HON03](#) or [BTH-HON03](#)
3. **Will I have to disconnect Satellite radio or separate (external) CD changer?**
NO. For the BTA-HON03 to work vehicle must have at least one external player (CD changer, Satellite radio or RSE) which remains connected and functional
4. **My vehicle has a Satellite radio tuner, but subscription has expired (Only able to tune preview channel), will the BTA-HON03 still work?**
YES. The BTA-HON03 will work and Satellite radio tuner must remain in vehicle. If subscription has expired (and vehicle DOES NOT have a remote CD Changer), AUX input jack is provided to which users may connect and play portable audio devices. If subscribed, the service remains functional- not aux jack provided.
5. **My vehicle has a remote CD changer. Will the BTA-HON03 work?**
YES. The BTA-HON03 will work and remote CD changer will also continue to work. Please ensure at least one disc remains in changer magazine.

* Remote CD changer refers to option installed in lower dash, glovebox, armrest, hatch, trunk etc. **CD changer built-into AM/FM radio is internal (not external) and remains functional. Satellite radio subscription is not disrupted.**

Disclaimer

- This product has no affiliation with Honda/Acura
- We're not liable for misuse of this product.
- We recommend professional installation

Email support@discountcarstereo.com

1995-January 25 Discount Car Stereo. All rights reserved. Information in this document is subject to change without notice. Other products and companies referred to herein are trademarks or registered trademarks of their respective companies or mark holders.